

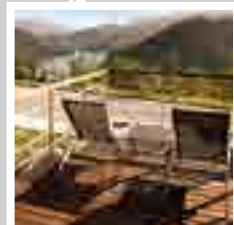

SIPHONS ABLÄUFE

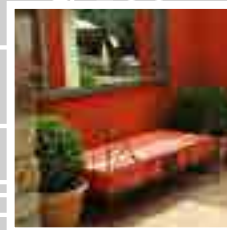

Ø 300



HL Products

Ø 145

14. Sealing kits
Extensions

14

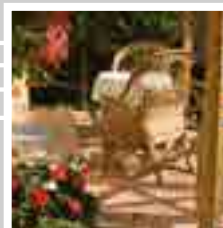

HL Sealing kits – Products – Overview

More details to the chapter „Sealing kits“ please see chapters floor drains, barrier free showers, balcony/terraces and waterproofing

For drain types	Kind of water proofing		
	For 2-component water proofings like epoxy resins or flexible sealing compounds	For EPDM sheetings, bitumen coatings; weldable with bitumen sheetings	For welding of bitumen sheetings
HL83.M = HL70, HL80, HL90, HL92, HL300, HL304, HL310-series, HL510-series Extension: HL85N	 <p style="text-align: center;">HL83.M</p>	 <p style="text-align: center;">HL83</p>	 <p style="text-align: center;">HL83.H *</p>
HL3100(T) and HL5100(T) Extension: HL8500	 <p style="text-align: center;">HL8300.M</p>	 <p style="text-align: center;">HL8300</p>	 <p style="text-align: center;">HL8300.H *</p>
HL72.1 and HL317 Extension: HL350.1	 <p style="text-align: center;">HL84.M</p>	 <p style="text-align: center;">HL84</p>	<p style="text-align: center;">**</p>
HL615 and HL616 Extension: HL618	 <p style="text-align: center;">HL86.M</p>	 <p style="text-align: center;">HL86</p>	 <p style="text-align: center;">HL86.H</p>
Roof drain types HL62, HL63, HL64 and HL69 Extension: HL65	 <p style="text-align: center;">HL84.L</p>	<p style="text-align: center;">-</p>	 <p style="text-align: center;">HL84.H</p>















* also available as drain with prefabricated bitumen flange at drain series HL80, HL615, HL616, roof drain series HL62, HL64, HL63, HL69 and extensions HL85, HL618, HL65.

















** available as drain with prefabricated insulation flange!

*** Sealing kit connectable (without sheeting) with on-site sheetings

PVC-sheetings	FPO-sheetings	For clamping of elastic on-site sheetings	Roofs with copper sheeting	Zinc-plated steel roofs
			-	-
HL83.P	HL83.PP	HL83.0		
			-	-
HL8300.P	HL8300.PP	HL8300.0		
***	***		-	-
		HL84.0		
***	***		-	-
		HL86.0		
**	**	**		
			HL84.CU	HL84.E

HL Extensions – Products – Overview







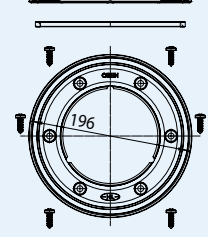

For drain types	For the height adjustment; Connection to 2-component water proofings	For the height adjustment of the flange	For the height adjustment; Connection to bitumen sheetings
HL70, HL80, HL90, HL300, HL304, HL310-series, HL510-series	 <p>HL85N + HL83.M</p>	 <p>HL85N</p>	 <p>HL85NH</p>
HL3100 and HL5100	 <p>HL8500 + HL8300.M</p>	 <p>HL8500</p>	 <p>HL8500H</p>
HL72.1 and HL317	 <p>HL350.0</p>	 <p>HL350.0</p>	 <p>HL350.1H</p>
HL615 and HL616	 <p>HL618 + HL86.M</p>	 <p>HL618</p>	 <p>HL618H</p>
Roof drain types HL62 and HL64	-	 <p>HL65</p>	 <p>HL65H</p>
Balcony and terrace drain HL92	-	-	-

For the height adjustment; Connection to PVC sheetings	For the height adjustment; Connection to FPO sheetings	For the elongation of the extension
 <p>HL85N + HL83.P</p>	 <p>HL85N + HL83.PP</p>	 <p>HL340N</p>
 <p>HL8500 + HL8300.P</p>	 <p>HL8500 + HL8300.PP</p>	 <p>HL3400</p>
 <p>HL350.0</p>	 <p>HL350.0</p>	 <p>HL350</p>
 <p>HL618 + HL86.0</p>	 <p>HL618 + HL86.0</p>	 <p>HL620</p>
 <p>HL65P</p>	 <p>HL65F (HL65PE)</p>	 <p>HL350</p>
<p>-</p>	<p>-</p>	 <p>HL320</p>

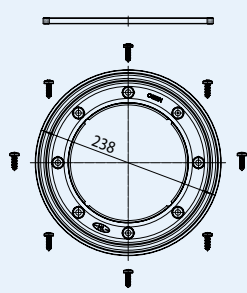
HL Sealing kits – Products – Data

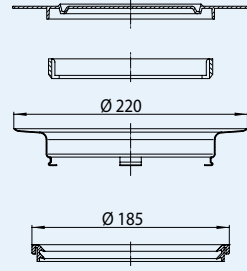
HL83.0, HL8300.0, HL84.0, HL86.0 Sealing kit without water proofing

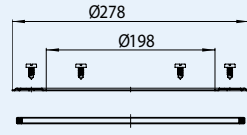
Data	
Material	Stainless steel V2A
Dimension	HL83.0: Ø 196 x 114 mm HL8300.0: Ø 238 x 148 mm HL84.0: Ø 220 x 155 mm HL86.0: Ø 278 x 198 mm
Recommended for	Connection of on-site sheetings to the flange
Fits to	HL83.0: HL70, HL80, HL90, HL92, HL300, HL304, HL310-series, HL510-series and extension element HL85N HL8300.0: HL3100(Pr) and HL5100(Pr) and extension HL8500 HL84.0: HL72.1 and HL317 HL86.0: HL615 and HL616 and extension HL618

<p>HL83.0</p>  	 <p>HL083.1E HL083.2E HL01023D</p>
<p>HL8300.0</p>  	 <p>HL086.1E HL08300.2E HL01092D</p>
<p>HL84.0</p>  	 <p>HL062B.3E HL084.2E HL084.4E</p>
<p>HL86.0</p>  	 <p>HL086.1E HL086.2E HL086.0E</p>

HL-No.	Weight	EAN	Piece/package
83.0	245 g	+718306	1
8300.0	303 g	+025497	1
84.0	395 g	+718405	1
86.0	340 g	+711864	1

HL83.M, HL8300.M, HL84.M, HL86.M Sealing kit with textile coated membrane
Data

Material	Stainless steel V2A/ Textile coated membrane
Dimension	HL83.M: Flange Ø 196 x 114 mm Textile coated membrane 400 x 500 mm HL8300.M: Flange Ø 238 x 148 mm Textile coated membrane 500 x 500 mm HL84.M: Flange Ø 220 x 155 mm Textile coated membrane 500 x 500 mm HL86.M: Flange Ø 278 x 198 mm Textile coated membrane 500 x 500 mm
Recommended for	2-component water proofings like epoxy resins or flexible sealing compounds
Fits to	HL83.M: HL70, HL80, HL90, HL92, HL300, HL304, HL310-series, HL510-series and extension element HL85N HL8300.M: HL3100(Pr) und HL5100(Pr) and Extension HL8500 HL84.M: HL72.1 und HL317 HL86.M: HL615 und HL616 and Extension HL618

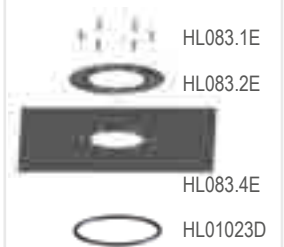
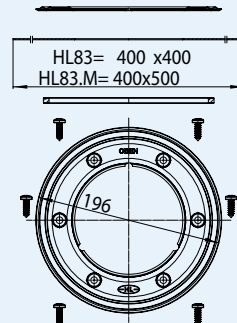
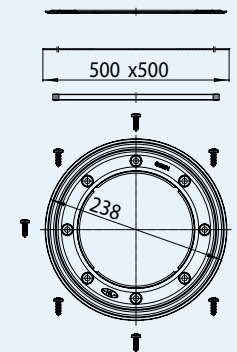
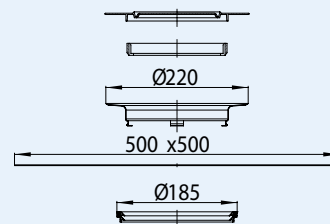
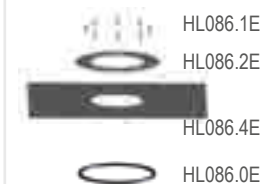
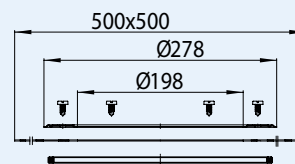
HL83.M

HL8300.M

HL84.M

HL86.M

HL-No.	Weight	EAN	Piece/package
83.M	425 g	+030835	1
83.3020	425 g	+034307	1
8300.M	425 g	+025473	1
84.M	730 g	+030842	1
86.M	590 g	+713868	1

HL83, HL8300, HL84, HL86 Sealing kit with EPDM-sheet

Data

Material	Stainless steel V2A/ EPDM
Dimension	<p>HL83: Flange Ø 196 x 114 mm EPDM-sheet 400 x 400 mm</p> <p>HL8300: Flange Ø 238 x 148 mm EPDM-sheet 500 x 500 mm</p> <p>HL84: Flange Ø 220 x 155 mm EPDM-sheet 500 x 500 mm</p> <p>HL86: Flange Ø 278 x 198 mm EPDM-sheet 500 x 500 mm</p>
Recommended for	EPDM sheetings, bitumen coatings; weldable with bitumen sheetings
Fits to	<p>HL83: HL70, HL80, HL90, HL92, HL300, HL304, HL310-series, HL510-series and extension element HL85N</p> <p>HL8300: HL3100(Pr) and HL5100(Pr) and Extension HL8500</p> <p>HL84: HL72.1 and HL317</p> <p>HL86: HL615 and HL616 and Extension HL618</p>

HL83

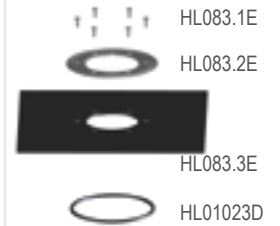
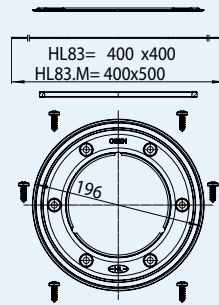
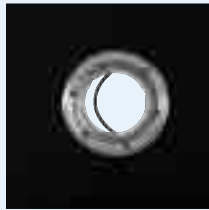

HL8300

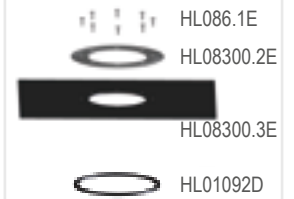
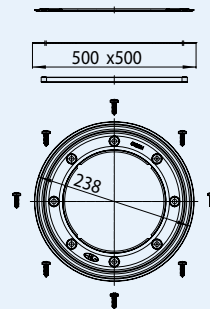
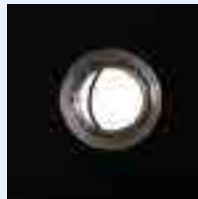

HL84

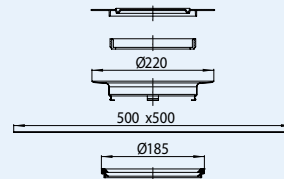
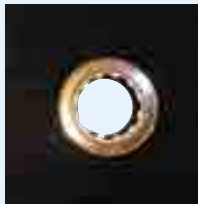

HL86

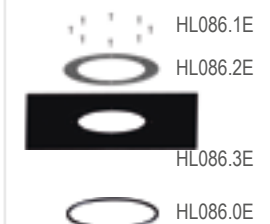
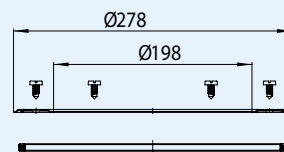
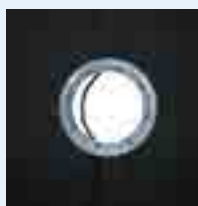

HL-No.	Weight	EAN	Piece/package
83	425 g	+710836	1
8300	601 g	+025466	1
84	730 g	+710843	1
86	590 g	+710867	1

HL83.H, HL8300.H, HL84.H, HL86.H Sealing kit with bitumen sheet

Data

Material	Stainless steel V2A/ bitumen
Dimension	HL83.H: Flange Ø 196 x 114 mm Bitumen collar 500 x 500 mm
	HL8300.H: Flange Ø 238 x 148 mm Bitumen collar 500 x 500 mm
	HL84.H: Flange Ø 220 x 155 mm Bitumen collar 500 x 500 mm
	HL86.H: Flange Ø 278 x 198 mm Bitumen collar 500 x 500 mm

Recommended for Welding of bitumen water proofings

Fits to **HL83.H:** HL70, HL80, HL90, HL92, HL300, HL304, HL310-series, HL510-series as well as extension element HL85N
HL8300.H: HL3100(Pr) und HL5100(Pr) and Extension HL8500
HL84.H: Roof drain types: HL62, HL64, HL63, Extension: HL65
HL86.H: HL615 und HL616 and Extension HL618

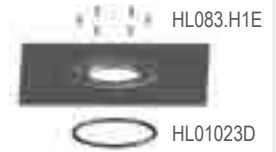
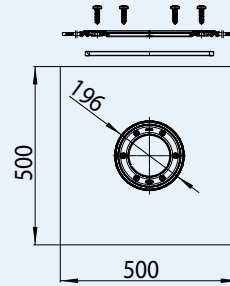
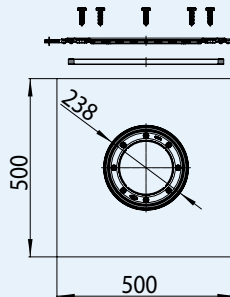
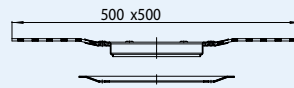
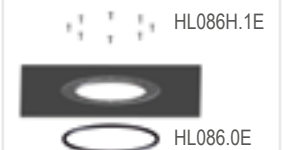
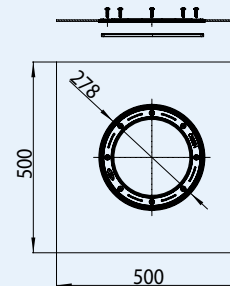
HL83.H

HL8300.H

HL84.H

HL86.H

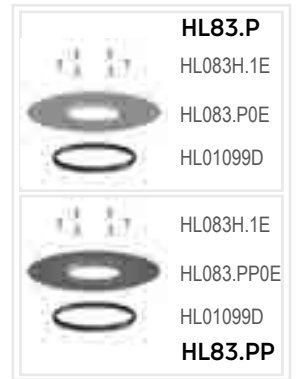
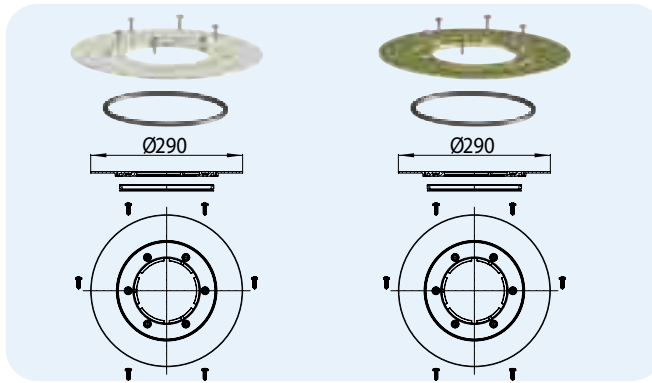
HL-No.	Weight	EAN	Piece/package
83.H	1560 g	+008315	1
8300.H	1560 g	+025480	1
84.H	1707 g	+011841	1
86.H	1590 g	+008612	1

HL83.P, HL83.PP Sealing kit with PVC or PP flange

Data	
Material	HL83.P: PVC HL83.PP: PP
Dimension	HL83.P: Flange Ø 290 mm HL83.PP: Flange Ø 290 mm
Recommended for	HL83.P: PVC sheetings HL83.PP: FPO sheetings, based on PP
Fits to	HL70, HL80, HL90, HL92, HL300, HL304, HL310-series, HL510-series as well as extension element HL85N



HL-No. 83.P	Weight 425 g	EAN +010837	Piece/package 1
83.PP	653 g	+028641	1

HL8300.P, HL8300.PP Sealing kit with PVC- respectively PP flange

Data	
Material	HL8300.P: PVC HL8300.PP: PP
Dimension	HL8300.P: Flange Ø 350 mm HL8300.PP: Flange Ø 350 mm
Recommended for	HL8300.P: PVC waterproofings HL8300.PP: FPO waterproofings, based on PP
Fits to	Drain series HL3100 and HL5100, extension HL8500

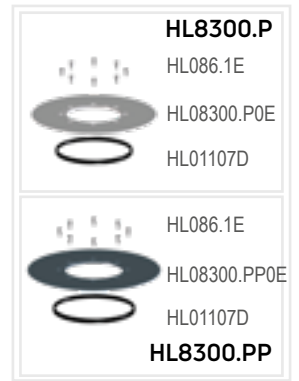
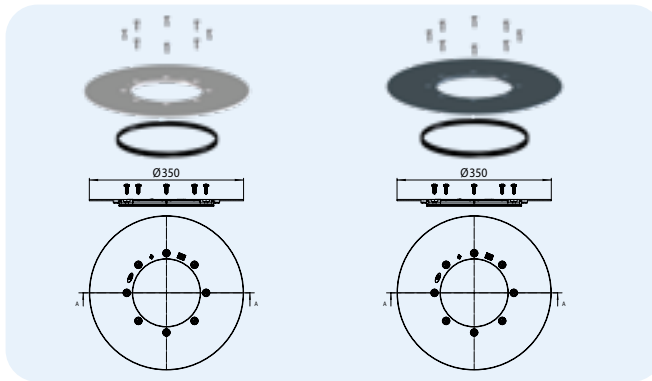

HL-No. 8300.P	Weight 530 g	EAN +034741	Piece/package 1
8300.PP	320 g	+034758	1

HL84.CU, HL84.E Sealing kit with copper collar or zinc-plated collar

Data	
Material	HL84.CU: Copper HL84.E: Zinc-plated steel
Dimension	HL84.CU: 500 x 500 mm HL84.E: 500 x 500 mm
Recommended for	HL84.CU: Copper roof sheetings HL84.E: Zinc-plated roof sheetings
Fits to	Roof drain series HL62, HL63, HL64, HL65 and HL69

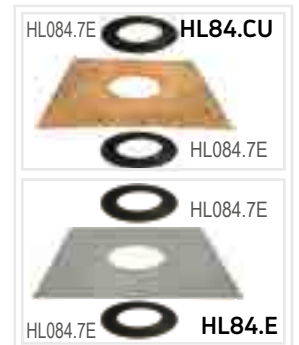
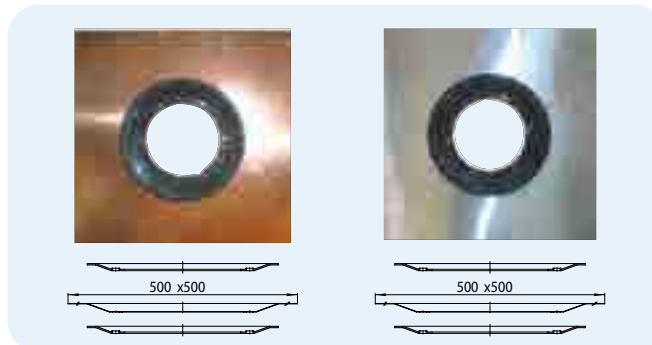

HL-No. 84.CU	Weight 1835 g	EAN +444847	Piece/package 1
84.E	1830 g	+111848	1

HL84.L Fleece-laminated membrane with TPE clamping area for liquid-waterproofing

Data	
Material	TPE, Fleece-laminated foil
Dimension	500 x 500 mm
Recommended for	Solvent-free liquid-waterproofings
Fits to	HL62, HL64, HL65 with clamping ring

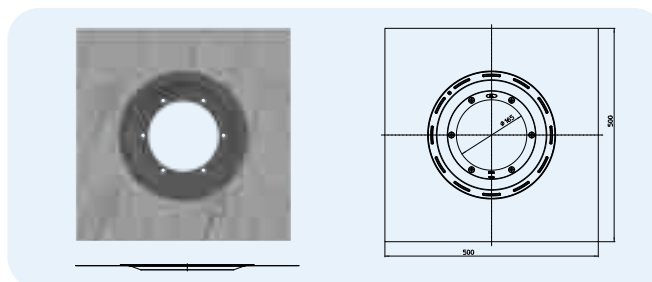

HL-No. 84.L	Weight 730 g	EAN +000739	Piece/package 1
----------------	-----------------	----------------	--------------------

HL Extensions – Products – Data

HL320, HL340N, HL3400, HL350, HL620 Extension

Data

Material	PP
Dimension	HL320: Ø 90 mm, h: 35 mm HL340N: Ø 110 mm, h: 100 mm HL3400: Ø 146 mm, h: 200 mm HL350: Ø 145 mm, h: 130 mm HL620: Ø 195 mm, h: 100 mm
Recommended for	Height adjustment of the drain
Fits to	HL320: HL92 HL340N: HL70, HL80, HL90, HL300, HL304, HL310-series, HL510-series and extension element HL85N HL3400: Series HL3100 and HL5100 HL350: HL72.1, HL317, HL62, HL63, HL64, HL65, HL69 HL620: HL615 und HL616

HL320

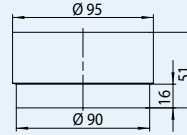

HL340N

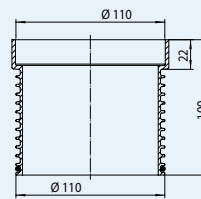

HL01067D

HL3400

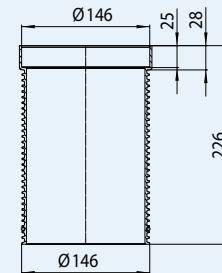

HL01093D

HL350

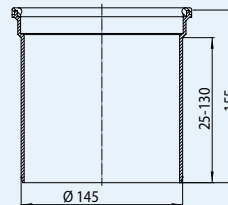

HL620

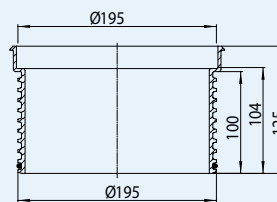

HL01056D

HL-No.	Weight	EAN	Piece/package
340N	75 g	+003402	1
3400	117 g	+025565	1
350	240 g	+703500	1
620	270 g	+014255	1

HL85N, HL8500, HL350.1, HL350.0, HL618, HL65 Extension with flange
Data

Material	PP
Dimension	HL85N: Ø 110 x 220 mm, h: 204 mm HL8500: Ø 146 x 239 mm, h: 202 mm HL350.1 (HL350.0): Ø 145 x 300 mm, h: 180 mm HL618: Ø 195 x 315 mm, h: 95 mm HL65: Ø 125 x 354 mm, h: 260 mm
Recommended for	Height adjustment of the drain to the water proofing level
Fits to	HL85N: HL70, HL80, HL90(Pr), HL300, HL304, HL310-series, HL510-series HL8500: HL3100(Pr) and HL5100(Pr) HL350.1 (HL350.0): HL72.1, HL317, HL62, HL63, HL64, HL65 and HL69 HL618: HL615, HL616 HL65: HL62, HL64

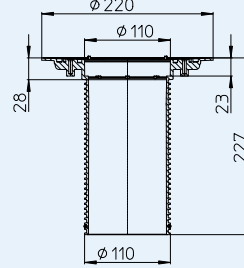
HL85N

HL01067D

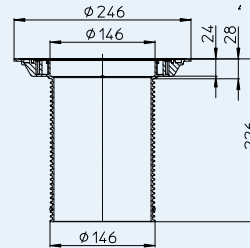
HL8500

HL03100.0E

HL01093D

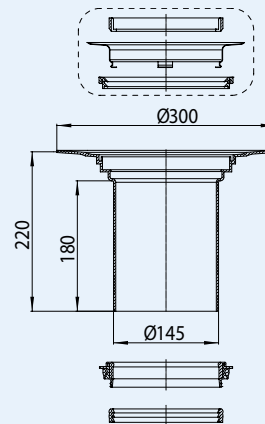
HL350.1 (HL350.0)

HL062B.3E

HL084.2E

HL084.3E

HL084.4E

HL01059D HL01058D

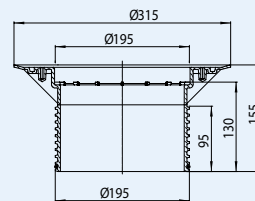
HL618

HL01056D

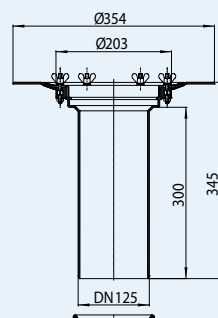
HL65

HL062.4E

HL170

HL062.3E

HL01020D

HL-No.	Weight	EAN	Piece/package
85N	395 g	+006120	1
8500	320 g	+025572	1
350.0	680 g	+032358	1
350.1	1440 g	+703517	1
618	500 g	+013159	1
65	1440 g	+800650	1

HL85NH, HL8500H, HL350.1H, HL618H, HL65H Extension with bitumen welded flange
Data

Material	PP / stainless steel / bitumen
Dimension	HL85NH: Ø 110 mm, h: 204 mm, Bitumen collar: Ø 420 mm HL8500H: Ø 146, h: 202 mm, Bitumen collar: 500 x 500 mm HL350.1H: Ø 145, h: 180 mm, Bitumen collar: Ø 500 mm HL618H: Ø 195 mm, h: 95 mm, Bitumen collar: 500 x 500 mm HL65H: Ø 125 mm, h: 260 mm, Bitumen collar: Ø 500 mm
Recommended for	Bitumen waterproofings
Fits to	HL85NH: HL70, HL80, HL90, HL300, HL304, HL310-series, HL510-series HL8500H: HL3100(Pr)(T), HL5100 (Pr)(T) HL350.1H: HL72.1, HL317, HL62, HL63, HL64, HL65, HL69 HL618H: HL615 and HL616 HL65H: HL62, HL64

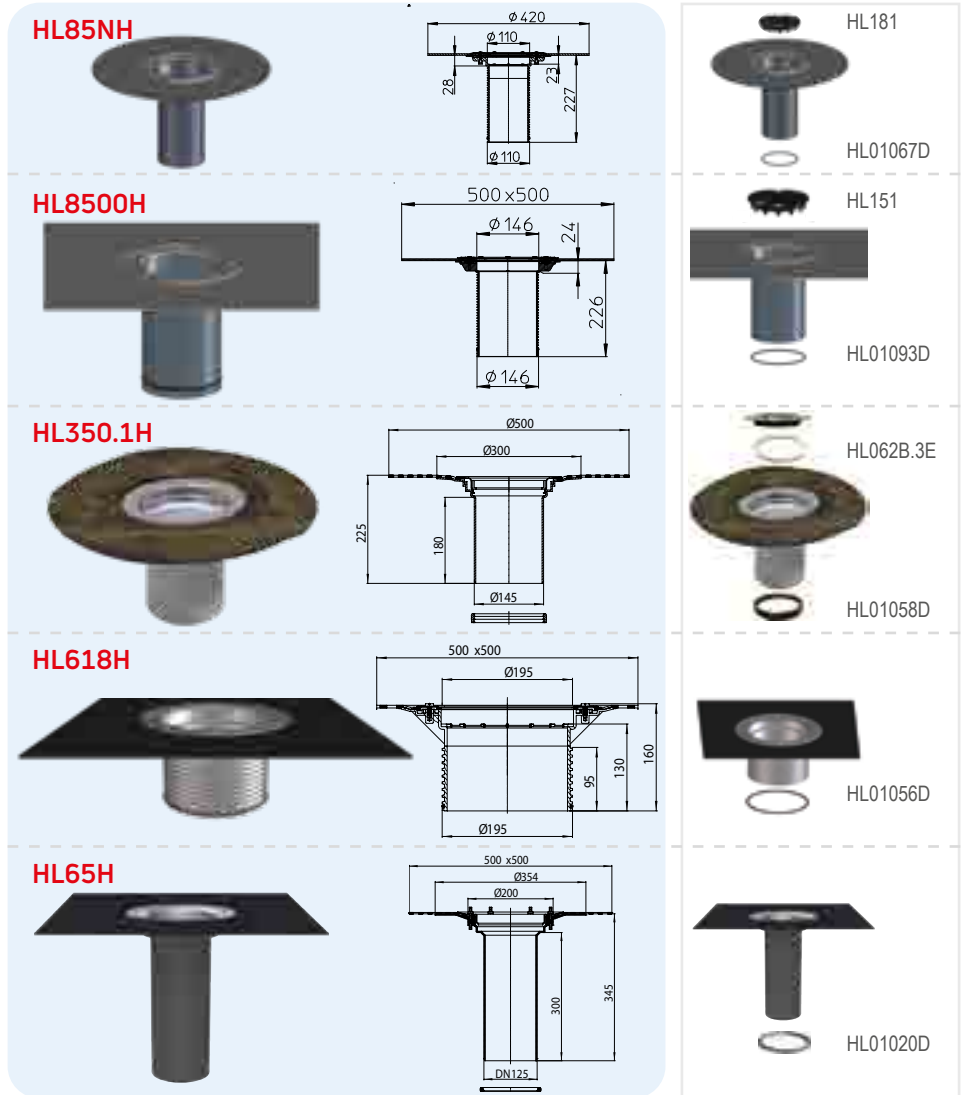

HL-No.	Weight	EAN	Piece/package
85NH	980 g	+009015	1
8500H	2346 g	+034765	1
350.1H	1550 g	+001842	1
618H	1750 g	+013173	1
65H	2140 g	+801657	1

HL65P, HL65F, HL65PE Extension with PVC flange or PP flange
Data

Material	HL65P: PVC HL65F: PP HL65PE: PE
Dimension	HL65P: Ø 125 mm, h: 350 mm, Flange: Ø 354 mm HL65F, HL65PE: Ø 125 mm, h: 345 mm, Flange: Ø 355 mm
Recommended for	HL65P: PVC roof sheetings HL65F: FPO roof sheetings, based on PP HL65PE: FPO roof sheetings, based on PE
Fits to	roof drains HL62 and HL64

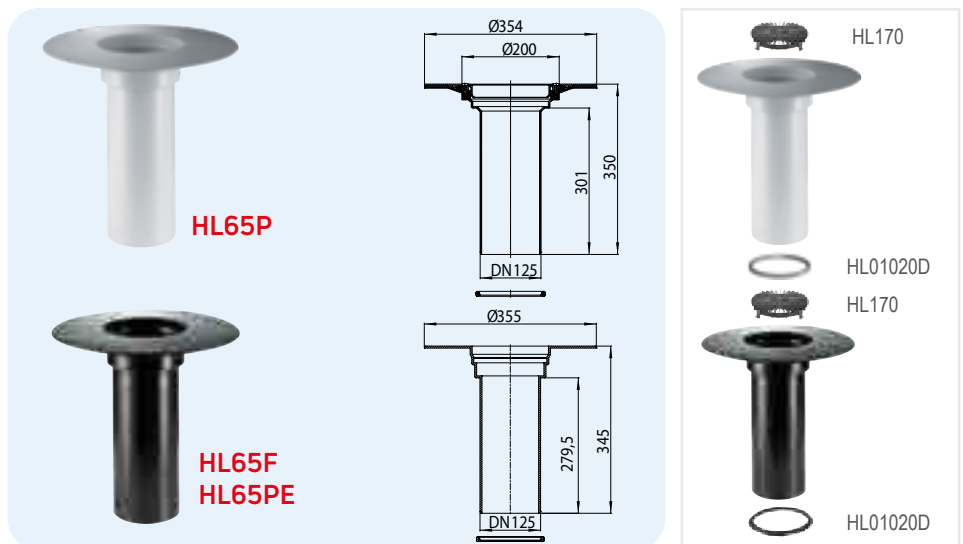

HL-No.	Weight	EAN	Piece/package
65P	1370 g	+022588	1
65F	830 g	+031900	1
65PE	850 g	+035915	1



SIPHONS ABLÄUFE